

*Hempert*<sup>®</sup>

Certified



This company meets the  
highest standards of social  
and environmental impact

---

Corporation



Somos una historia

de **impacto**







# Nepal

नेपाल

27°46'47.8"N

85°21'47.7"E





*Hemper*<sup>®</sup>

Certified



Corporation





Certified



Corporation





*Yellow  
Go Kyo*



*Nimona*



*Look 1*



*Yellow*

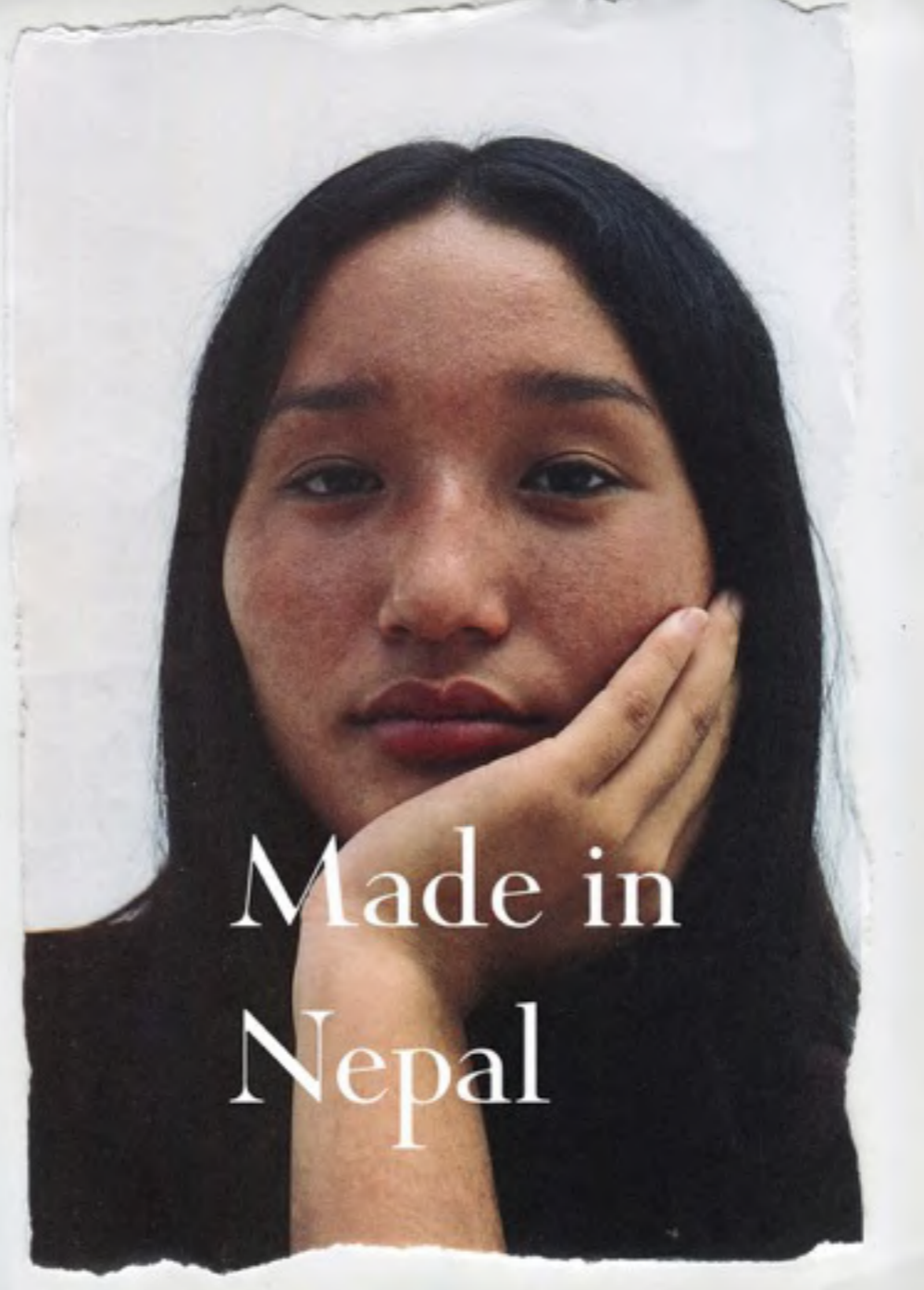

Made in  
Nepal

Cómo planteamos nuestro modelo  
de empresa?

# Triple Balance

बलांस



economics

social



environmental





## 1. Impacto operativo - “Doing things impactfully”

Gestión del impacto a través de la actividad diaria de la empresa

## 2. Modelo de negocio de Impacto - “Doing impactful things”

El diseño de la empresa crea un impacto positivo específico en uno o varios grupos de interés

Cuál es nuestra misión de impacto?



# La teoría de cambio se puede plasmar en una plantilla

1. **Misión de la iniciativa/organización:**Cuál es la misión, el fin último que pretendemos alcanzar

## 2. Problema /Reto que intentas resolver

- Descripción del problema, por qué las soluciones actuales no funcionan, qué barreras existen...
- **Magnitud del problema, situación geográfica etc.**

## 6. ¿Cuál será su impacto?

- Impacto esperado (positivo o negativo), a ser posible indicando los indicadores de medición y metodologías que se utilizarán, y previsión cuantificada de impacto
- Se deben tener en cuenta los distintos actores implicados, e impactos tanto directos como indirectos
- Deben haber indicadores que permitan decir si se está alcanzando la misión



## 3. Solución que propones

Descripción de la actividad general que se propone la organización para solucionar el problema. También se puede describir aquí el rol que distintas partes deben adoptar para que el problema se pueda solucionar, reconociendo que raramente una sola organización es suficiente



## 5. ¿Qué actividades realizar?

- Actividades clave que deberá realizar la organización para llevar a buen puerto la solución



## 4. ¿Qué cosas asumes para tu teoría de cambio?

Este apartado es clave ya que permite reflexionar sobre que condiciones deben darse para que esta teoría de cambio funcione en realidad. Debemos cuestionarnos si las actividades tendrán el efecto deseado y por qué, si el diagnóstico del problema está completo etc. Es importante sobretodo al principio intentar comprobar la validez de la teoría de cambio y cuestionarse este apartado para asegurarnos de que alcanzamos el impacto esperado en lugar de crear un problema mayor.

Promover la moda sostenible, a la vez que contribuimos al desarrollo socioeconómico de Nepal mediante una cadena de valor con impacto positivo



# Environmental impact

1. What materials are we using?
2. How much waste I am creating?
3. What can we do with that waste? how can I reduce it?
4. How can we recycle the materials from the product?



www.made-by.org

# MADE-BY ENVIRONMENTAL BENCHMARK FOR FIBRES

CLASS A	CLASS B	CLASS C	CLASS D	CLASS E	UNCLASSIFIED
Mechanically Recycled Nylon	Chemically Recycled Nylon	Conventional Flax (Linen)	Modal® (Lenzing Viscose Product)	Bamboo Viscose	Acetate
Mechanically Recycled Polyester	Chemically Recycled Polyester	Conventional Hemp	Poly-acrylic	Conventional Cotton	Alpaca Wool
Organic Flax (Linen)	CRAILAR® Flax	PLA	Virgin Polyester	Generic Viscose	Cashmere Wool
Organic Hemp	In Conversion Cotton	Ramie		Rayon	Leather
Recycled Cotton	Monocel® (Bamboo Lyocell Product)			Spandex (Elastane)	Mohair Wool
Recycled Wool	Organic Cotton			Virgin Nylon	Natural Bamboo
	TENCEL® (Lenzing Lyocell Product)			Wool	Organic Wool
					Silk
More Sustainable			Less Sustainable		

© Copyright MADE-BY Label UK Ltd. MADE-BY Benchmarks cannot be printed, circulated or copied without the accompanying MADE-BY logo and website.

**bwe** This Benchmark was made in cooperation with Brown and Wilmanns Environmental, LLC. For further information on this Benchmark see [www.made-by.org/benchmarks](http://www.made-by.org/benchmarks)







hemp



plástico

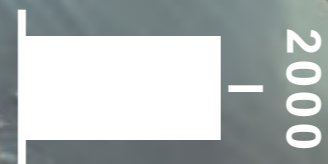

cuero

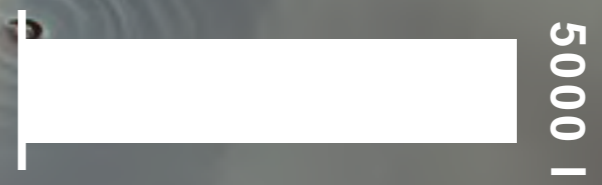

algodón

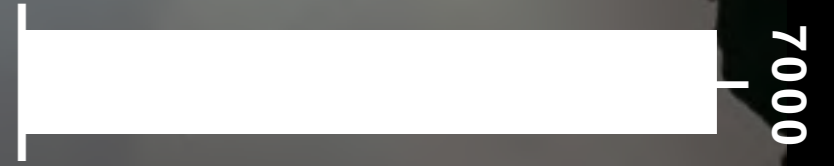

# Hemp-er

litros de agua por kg.





TRASH COLLECTION



TRASH IS OUR ZERO WASTE INITIATIVE: MAKING NEWLY UPCYCLED CLOTHES OUT OF FIBERS RECOVERED FROM POST-CONSUMER RECYCLED MATERIALS, ALONG WITH NEW SUSTAINABLE FIBERS.



Modelos de negocio basados en el  
pilar medio ambiental

Recycling or  
reusing materials



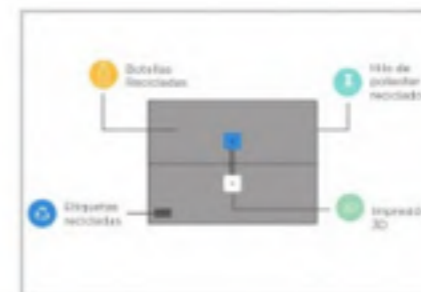
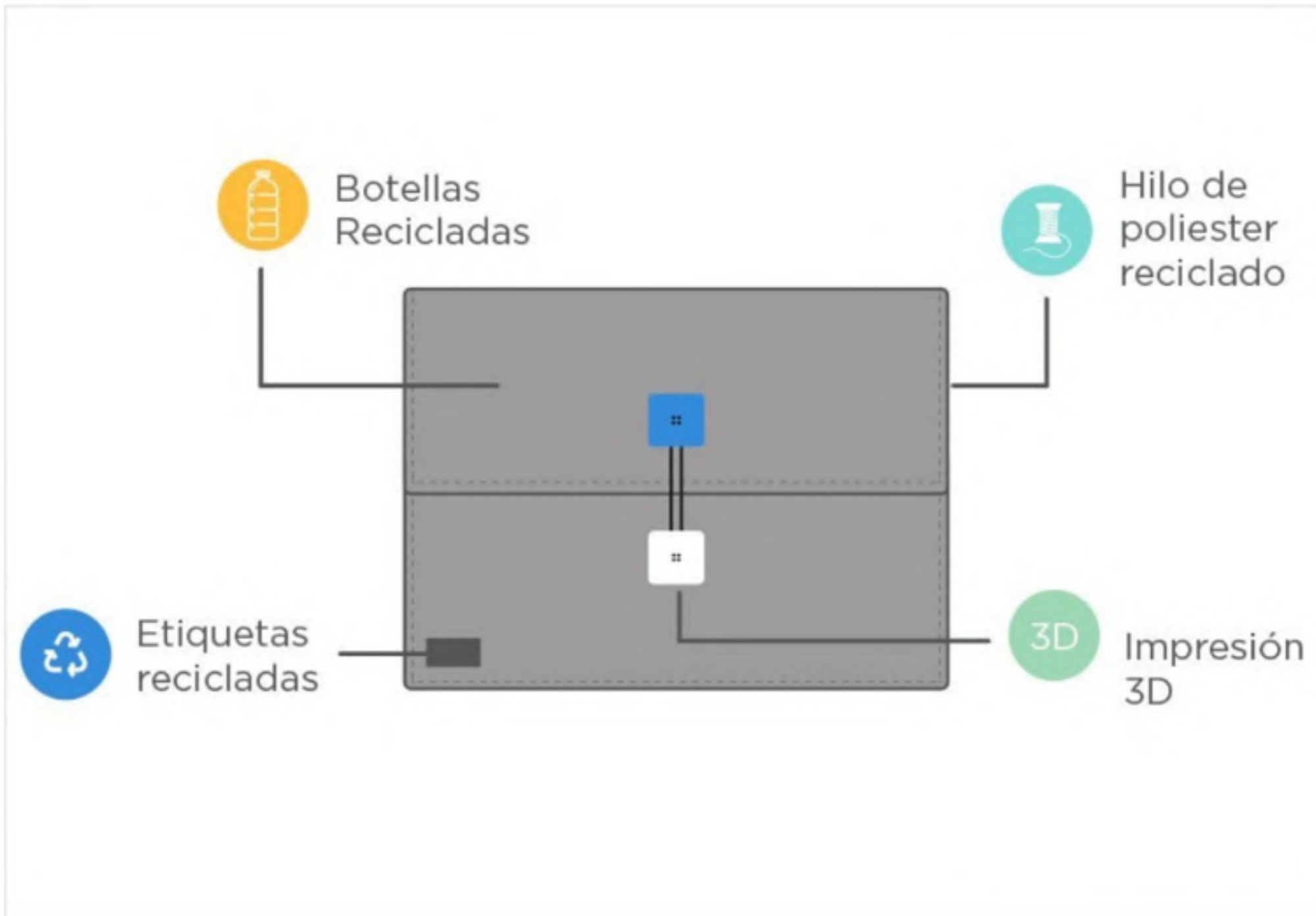



# Repair





# Repair Shops

We don't call our stores 'Repair Shops' for nothing. Just as important as selling jeans it is for us to repair what we once sold. Wash your jeans and hand them in at your closest Nudie Jeans Repair Shop. When they're done you have a new version of your old favourite. Making your mark on your things adds value to them and make them worth caring for.

The idea behind the Nudie Jeans Repair Shops is that they are hubs for our jeans to be repaired, resold as second-hand or even donated to the Nudie Jeans recycling program.





# REGALOS DE EMPRESA ECOLOGICOS

Expertos en detalles sostenibles de usar y plantar

[VER CATALOGO Y PRECIOS](#)



# Fleece & Insulation

Great for layering and with a lower carbon impact.

[Explore the collection](#)



# Social impact

1. How we bring wealth in to the society not only money?
2. How we have a positive impact?
3. How we create something beautiful?



Retrieve  
traditions







CADENA DE VALOR CON IMPACTO +

# GI



1. Productores de bajos recursos —>  
Agentes de cambio locales



2. Trabajadores de colectivos vulnerables —>  
productores



3. Hijos de los trabajadores y productores —>  
futuros emprendedores sociales



# Local change makers -

## Capacitación de proveedores:

- Mediante nuestra actividad, crear conjuntamente una industria justa y competitiva en Nepal alrededor del cáñamo -
- Siguiendo los estándares de fair trade en calidad, gestión y condiciones



# Producers

How can we empower vulnerable communities through tailoring?





# Children





# crear un entorno bonito





# crear un entorno bonito





# Clientes





# Economic sustainability

1. Product
2. Brand



# AYESHA. GIULIA'S HAND BAG

Supplier: MANUSHI

Fabric: Pure Hemp  
 LINING: Cotton + serán print in black  
 LABEL: Inside. 3,5cm up from the start of the handle. PLEASE CENTERED  
 ZIPPER: Metallic YKK  
 TRIM: Magnet Antique-brass  
 INSIDE LABEL: 100% Instructions Label  
 PADDED ALL: 3 LAYERS OF RICEBAG

Thread NOT Greenish  
 BIG STONES for BIG BAG  
 OTHER STONES for MEDIUM



## MEDIUM

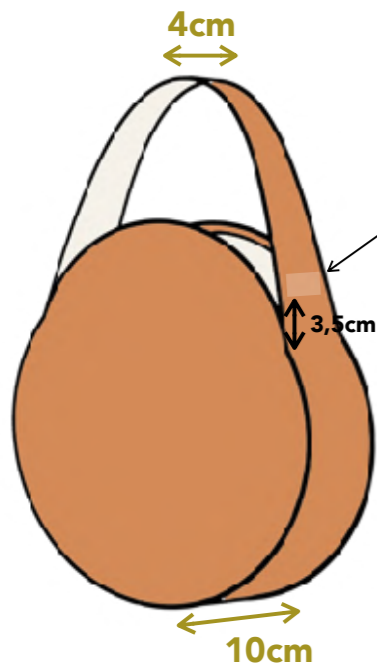

LABEL: INSIDE. 3,5cm up from the start of the handle. PLEASE CENTERED

## BIG

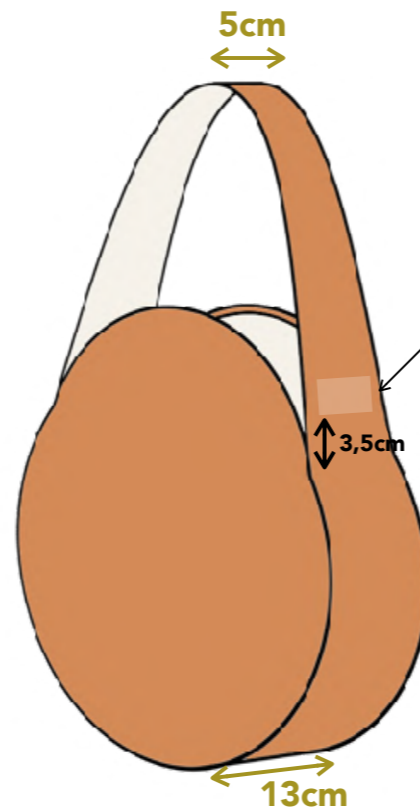
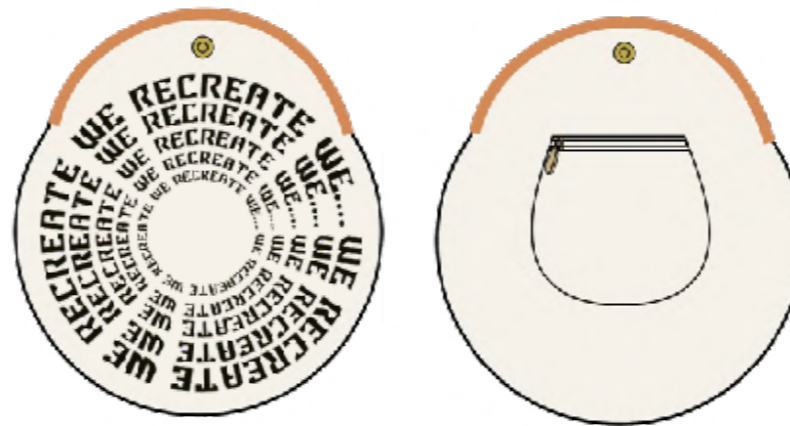

LABEL: INSIDE. 3,5cm up from the start of the handle. PLEASE CENTERED

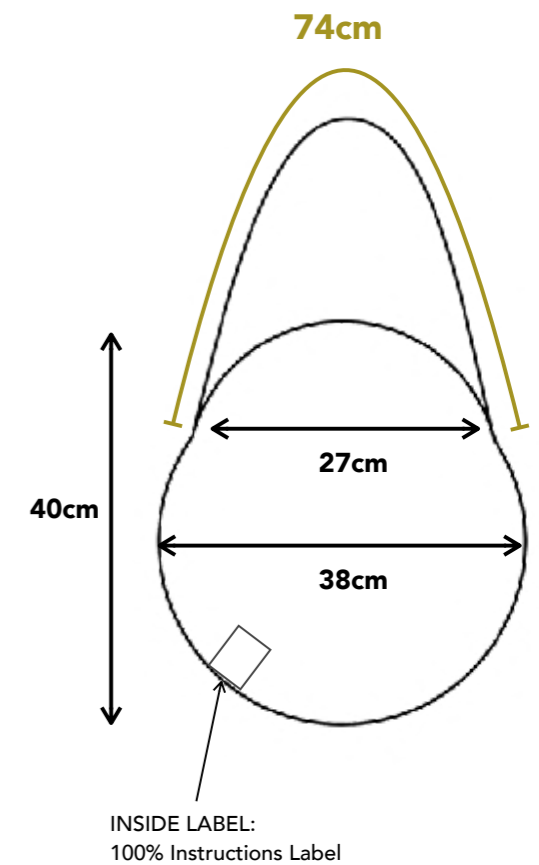
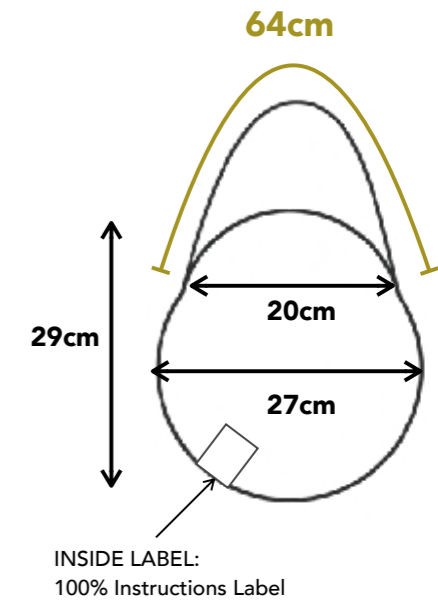

Update: 17/02/2020

Design: Manuel Quintero





hemper\_ Siguiendo

1.253 publicaciones 78k seguidores 628 seguidos

Made in Nepal
We are a story about culture, craft & impact. #SustainableFashion
#WeAllMakeImpact
hemper.es/pages/shop
issmonkeyface, brunoolle, nachserra6 y 332 más siguen esta cuenta



STORE...



BCORP



RICEB...



#OurPr...

PUBLICACIONES IGTV ETIQUETADAS



Modelo: A. S. / Contratto: /

*Hempes*



Made in  
Nepal

Se garantisce la qualità. La moda sostenibile della Hempes.  
Resistente agli acidi, lavabile in lavatrice, ecologica e facile da curare. Hempes è un marchio di Hempes.

Hempes & Adriano Rossi

Modelo: A. S. / Contratto: /

*Hempes*

# Made in Nepal



Se garantisce la qualità. La moda sostenibile della Hempes.  
Resistente agli acidi, lavabile in lavatrice, ecologica e facile da curare. Hempes è un marchio di Hempes.

MIL-CODE  
06







#ENVUELVELOMEJOR







Actualidad

## #Envuelvelomejor: El challenge por un packaging sostenible en las compras online

29 JUNIO, 2018

0



Por: [Laura Quelle](#)

Comienza el periodo de rebajas y aumentan las ventas en las tiendas online. En España se entregan de media más de 600.000 paquetes diarios, una cifra que va a crecer en este periodo de descuentos.

Los envoltorios de cada uno de estos envíos suponen una cantidad ingente de cartón y plásticos que generan una **huella medio ambiental evidente con unas 23 toneladas de basura al año**. Hasta ahora, el foco sólo se había puesto sobre las bolsas de plástico que se entregan en los comercios y en los supermercados y por las que el consumidor debe pagar unos céntimos. No sucede lo mismo con el *packaging* que afecta al comercio online y que cada vez tiene un mayor protagonismo, especialmente en la época de rebajas. De hecho, según la CNMC, **en las pasadas rebajas de enero los españoles gastaron en comercio electrónico un 23% más** que en el mismo periodo del año anterior.

La respuesta a esta situación la ha dado el equipo de **Hemper**. Los jóvenes que lideran esta firma de moda sostenible han creado la campaña **#envuelvelomejor** que anima a que



Financia las compras de tus clientes



RECIBE NUESTRA NEWSLETTER

\*Email:

\*Nombre apellidos:

\*Empresa:



# Ricebags, Ricebags, Ricebags







TENDENCIAS

## ¿Y si el 'it bag' del verano 2019 es una bolsa de arroz reciclada?

POR MARINA VALERA

10 DE ABRIL DE 2019

Hemper, la marca española de mochilas sostenibles, ha empezado a comercializar lo que hasta ahora era su packaging: bolsas de arroz nepalí recicladas



# *Campañas de comunicación*

@miempresaesnoticia



# Ronda financiación

## Hemper

Marca de moda sostenible basada en la tradición artesanal del cáñamo nepalí para crear productos social y medio ambientalmente justos.

### Condiciones de la inversión

Objetivo: 224.000 € - 350.000 €

Capital ofrecido: 20,00 - 28,00 %

Inversión mínima: 900 €



**313.305 €** FINANCIADOS

140%

**76**  
INVERSORES

**199**  
INTERESADOS

**31**  
DÍAS  
RESTANTES

QUIERO INVERTIR

♥ Me interesa

↻ Compartir

# Mide lo que Importa

El impacto social y medioambiental de su empresa.

Comenzar





#weallmakeimpact